

MICRO ROBUTO

MICROID - Swiss Type Internal Robuto

Internal diameters miniature Roller Burnishing Tools for Swiss Lathes.

Their short length allows them to be used on the reduced spaces in Swiss Lathes. With MICROID all the working can be done directly on the CNC machine avoiding the high cost and waste of time for secondary workings. The tools shown are examples, we can do a full customization to meet customer needs. (even shorter than the ones shown).

MICRO Tool Series offer a rear adjustment mechanism which allows the effective length of the tool to be kept compact.



MICROID

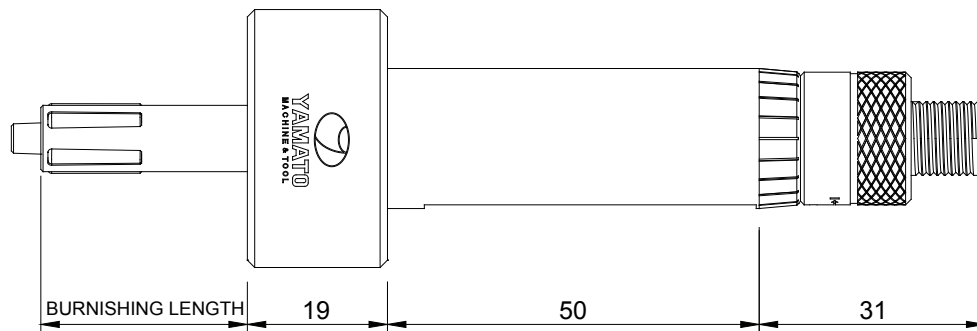

"Total length out of the chuck" is equal to ["burnishing length" + 19 mm]
 This value is equal to ["burnishing length" + 75 mm] on standard Roller Burnishing Tools